

Write your name here

Surname

Other names

Pearson
Edexcel GCE

Centre Number

--	--	--	--	--	--

Candidate Number

--	--	--	--	--

Physics

Advanced Subsidiary
Unit 2: Physics at Work

Thursday 8 June 2017 – Afternoon
Time: 1 hour 30 minutes

Paper Reference

6PH02/01

You must have:

Ruler

Total Marks

Instructions

- Use **black** ink or ball-point pen.
- **Fill in the boxes** at the top of this page with your name, centre number and candidate number.
- Answer **all** questions.
- Answer the questions in the spaces provided
– *there may be more space than you need.*

Information

- The total mark for this paper is 80.
- The marks for **each** question are shown in brackets
– *use this as a guide as to how much time to spend on each question.*
- Questions labelled with an **asterisk** (*) are ones where the quality of your written communication will be assessed
– *you should take particular care with your spelling, punctuation and grammar, as well as the clarity of expression, on these questions.*
- The list of data, formulae and relationships is printed at the end of this booklet.
- Candidates may use a scientific calculator.

Advice

- Read each question carefully before you start to answer it.
- Try to answer every question.
- Check your answers if you have time at the end.

Turn over ►

P53490A

©2017 Pearson Education Ltd.

1/1/1/1/1/



Pearson

SECTION A

Answer ALL questions.

For questions 1–10, in Section A, select one answer from A to D and put a cross in the box . If you change your mind, put a line through the box and then mark your new answer with a cross .

1 Which of the following is an SI base quantity?

- A ampere
- B charge
- C coulomb
- D current

(Total for Question 1 = 1 mark)

2 A motor is used to lift a mass m through a height h in a time t . When a current I is drawn from the power supply, the potential difference across the motor is V .

Which of the following is a correct expression for the efficiency of the system?

- A $\frac{VI}{mgh}$
- B $\frac{mgh}{VI}$
- C $\frac{mgh}{VIt}$
- D $\frac{VIt}{mgh}$

(Total for Question 2 = 1 mark)

DO NOT WRITE IN THIS AREA

DO NOT WRITE IN THIS AREA

DO NOT WRITE IN THIS AREA



DO NOT WRITE IN THIS AREA

DO NOT WRITE IN THIS AREA

DO NOT WRITE IN THIS AREA

3 Which of the following graphs shows the current-potential difference characteristics of a negative temperature coefficient (NTC) thermistor?

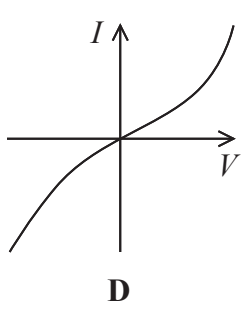
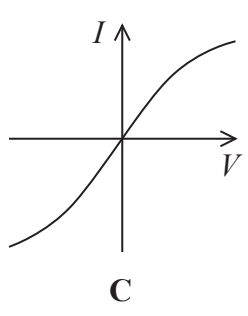
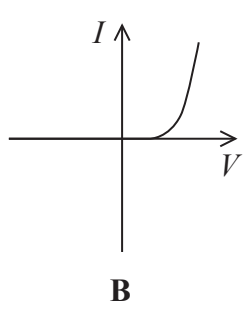
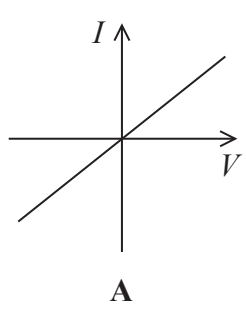

- A
- B
- C
- D

(Total for Question 3 = 1 mark)

4 Which of the following is **not** evidence for the wave nature of light?

- A diffraction
- B interference
- C polarisation
- D visible line spectra

(Total for Question 4 = 1 mark)

5 A lightning strike takes a time t . During the lightning strike electrons are discharged to Earth creating a current I .

An expression for the total number of electrons that are discharged to Earth during the lightning strike is

- A $\frac{It}{e}$
- B $\frac{I}{te}$
- C $\frac{e}{It}$
- D $\frac{te}{I}$

(Total for Question 5 = 1 mark)



- 6 Two nichrome wires are connected in parallel in a circuit. The wires are the same length but have different cross-sectional areas.

Which two properties have the same value in each wire?

- A charge carrier density and current
- B charge carrier density and potential difference
- C current and potential difference
- D drift velocity and resistance

(Total for Question 6 = 1 mark)

- 7 Einstein's photoelectric equation states

$$hf = \phi + \frac{1}{2}mv_{\max}^2$$

The term $\frac{1}{2}mv_{\max}^2$ represents which of the following quantities?

- A energy of photoelectron
- B energy of photon
- C ionisation energy
- D work function

(Total for Question 7 = 1 mark)



DO NOT WRITE IN THIS AREA

8 The temperature of a copper wire was decreased.

Which row in the table describes the effect on the number of conduction electrons and the resistance of the wire?

		Number of conduction electrons	Resistance
<input type="checkbox"/>	A	increased	decreased
<input type="checkbox"/>	B	increased	increased
<input type="checkbox"/>	C	unchanged	decreased
<input type="checkbox"/>	D	unchanged	increased

(Total for Question 8 = 1 mark)

9 An energy level diagram for hydrogen, with four possible transitions between levels, is shown.

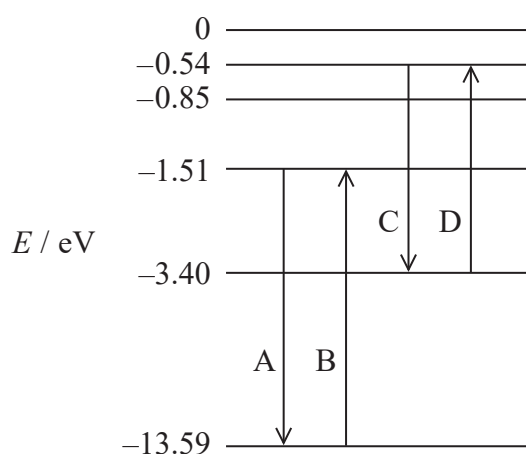

Which transition will result in the emission of radiation of the shortest wavelength?

- A
- B
- C
- D

(Total for Question 9 = 1 mark)

DO NOT WRITE IN THIS AREA



10 A progressive sound wave consists of a series of compressions and rarefactions.

Which of the following statements is **not** true?

- A At a compression the particles are at maximum displacement from equilibrium.
- B At a rarefaction the particles are at minimum displacement from equilibrium.
- C The distance from a compression to the adjacent rarefaction is equal to half the wavelength.
- D At a rarefaction the particles are further apart than at a compression.

(Total for Question 10 = 1 mark)

TOTAL FOR SECTION A = 10 MARKS



SECTION B

Answer ALL questions in the spaces provided.

11 A student plucks a guitar string, setting up a stationary wave on the string.

(a) Describe how a stationary wave is produced on the string.

(2)

.....

.....

.....

.....

(b) The student says “The wave on the string cannot be a stationary wave as I can hear the sound from the guitar and stationary waves do not transfer energy.”

Comment on the student’s statement.

(2)

.....

.....

.....

.....

.....

(Total for Question 11 = 4 marks)

DO NOT WRITE IN THIS AREA

DO NOT WRITE IN THIS AREA

DO NOT WRITE IN THIS AREA



12 A circuit is shown.

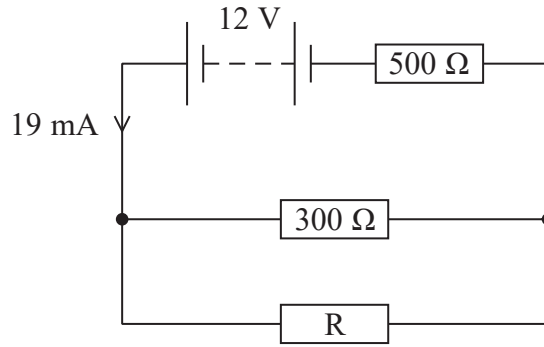

(a) Calculate the potential difference across the 500 Ω resistor.

(2)

Potential difference =

(b) Calculate the resistance of resistor R.

(4)

Resistance =

(Total for Question 12 = 6 marks)

DO NOT WRITE IN THIS AREA

DO NOT WRITE IN THIS AREA

DO NOT WRITE IN THIS AREA



DO NOT WRITE IN THIS AREA

DO NOT WRITE IN THIS AREA

DO NOT WRITE IN THIS AREA

13 Some owls emit sound as a low frequency 'hoot'. This enables them to communicate over large areas of woodland.

(a) Explain how a low frequency hoot enables the sound to have a large coverage over a woodland area.

(2)

.....

.....

.....

.....

(b) An owl is stationary, close to two trees. The trees are separated by a distance of 1.2 m.

Calculate the frequency of hoot that will give the sound the greatest coverage beyond the trees.

speed of sound in air = 340 ms^{-1}

(2)

.....

.....

.....

.....

Frequency =

(Total for Question 13 = 4 marks)



- 14 The diagram shows a circuit that can be used to determine the e.m.f. ε and internal resistance r of a power supply.

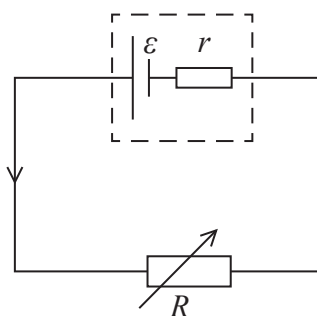

The resistance R is varied and corresponding values of terminal potential difference and current are recorded.

A graph of terminal potential difference against current is plotted.

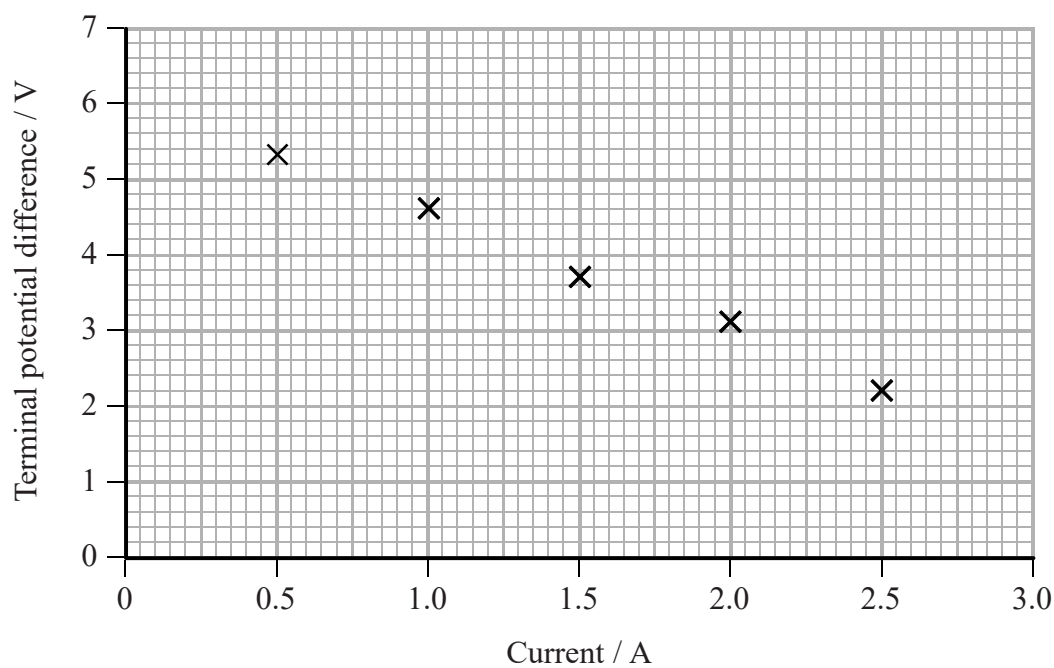

- (a) (i) Use the graph to determine a value for ε .

(2)

$\varepsilon =$



(ii) Use the graph to determine a value for r .

(2)

.....

.....

.....

.....

$r =$

(b) ε is given by the equation

$$\varepsilon = I(r + R)$$

Power supplies used in schools are designed to have a very large value of r .
Use the equation to explain how this keeps students safer.

(2)

.....

.....

.....

.....

(Total for Question 14 = 6 marks)

DO NOT WRITE IN THIS AREA

DO NOT WRITE IN THIS AREA

DO NOT WRITE IN THIS AREA



15 When a wire is stretched it becomes longer and thinner. This changes the electrical resistance of the wire. The resistance strain gauge is based on this idea.

- (a) Explain what effect stretching a length of wire would have on its resistance, using an equation to justify your answer.

(3)

- (b) The diagram shows a resistance strain gauge. The wire in the gauge is arranged in a zigzag pattern.

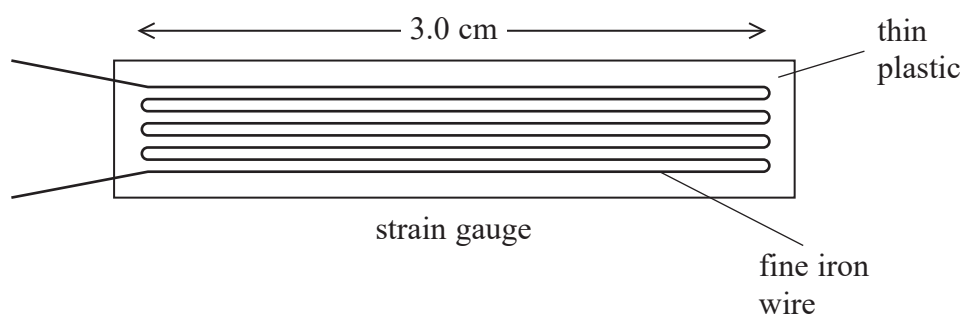

The length of the zigzag pattern is 3.0 cm and the cross-sectional area of the iron wire is $8.5 \times 10^{-8} \text{ m}^2$.

Show that the total resistance of the wire in the strain gauge is about 0.3Ω .

resistivity of iron = $9.9 \times 10^{-8} \Omega \text{ m}$

(3)



DO NOT WRITE IN THIS AREA

DO NOT WRITE IN THIS AREA

DO NOT WRITE IN THIS AREA

- (c) (i) A wire of length l and cross-sectional area A is stretched. Assuming the volume V of the wire remains constant, then

$$V = lA = \text{constant}$$

Show that the resistance of the wire is directly proportional to l^2 .

(2)

.....

.....

.....

- (ii) The length of the zigzag pattern when stretched increases to 3.02 cm.

Calculate the increase in resistance of the wire in the gauge.

(3)

.....

.....

.....

.....

.....

Increase in resistance of wire =

- (d) In practice, very small changes in length are to be determined and the gauge itself has to be reasonably small. Consequently, the gauge is made of a length of very fine iron wire which is arranged in a zigzag pattern between two thin sheets of plastic.

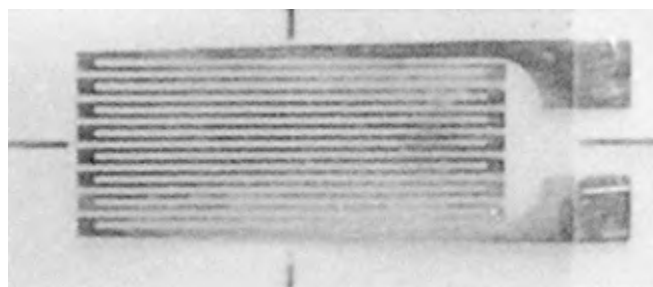

What is the benefit of the iron wire being in this pattern?

(2)

.....

.....

.....

(Total for Question 15 = 13 marks)



16 Bats hunt for prey using echolocation.

The bat emits ultrasound pulses that reflect off its prey. By detecting the reflected pulse the bat is able to determine the position and speed of the prey.



- (a) A stationary bat emits an ultrasound pulse. The bat detects the reflected pulse from a moth 15 ms later.

Calculate the distance of the moth from the bat.

speed of ultrasound in air = 340 m s^{-1}

(3)

Distance =

- (b) Bats can also determine the relative speed of a moving moth.

A stationary bat emits an ultrasound pulse with a wavelength of $5.40 \times 10^{-3} \text{ m}$.

The bat detects the wavelength of the reflected pulse as $5.45 \times 10^{-3} \text{ m}$.

- (i) State with justification whether the moth is moving towards or away from the bat.

(1)



(ii) The relative speed of the moth can be approximated by

$$v = 170 \left(\frac{\Delta\lambda}{\lambda} \right)$$

where

$\Delta\lambda$ = change in wavelength between the pulse emitted by the bat and the pulse received by the bat

λ = emitted wavelength from the bat.

Determine the relative speed of the moth.

(2)

.....

.....

.....

.....

Relative speed of moth =

(iii) State why the actual speed of the moth may be greater than this.

(1)

.....

.....

.....

.....

.....

(Total for Question 16 = 7 marks)

DO NOT WRITE IN THIS AREA

DO NOT WRITE IN THIS AREA

DO NOT WRITE IN THIS AREA



17 Iceland spar is a mineral that exists as large crystals of calcium carbonate.

Due to the crystalline structure, when unpolarised light is incident on the surface of a piece of Iceland spar the light is split into two rays. The two rays are polarised at right angles to each other.

*(a) When a piece of the crystal is placed over some writing, two images of the writing are visible.



Explain how a polarising filter can be used to demonstrate that the two images are formed by rays of light that are polarised perpendicularly to each other.

(3)

.....

.....

.....

.....

.....

.....



- (b) (i) Unpolarised light enters the crystal at an angle of incidence of 32° . As the light splits into two rays one of the rays is refracted with an angle of refraction of 19° .

Calculate the refractive index for light entering the Iceland spar.

(2)

.....
.....
.....

Refractive index =

- (ii) With the same angle of incidence, the second ray is refracted with a smaller angle of refraction. In this situation the refractive index for the second ray is greater than the refractive index for the first ray.

With reference to an appropriate equation, compare the speed of light through the crystal for the two rays.

(2)

.....
.....
.....
.....

(Total for Question 17 = 7 marks)



18 Noise-cancelling headphones are worn by pilots to protect their hearing from the continuous low frequency noise of the aircraft engine. A microphone samples the noise and a sound wave is produced inside the headphones that cancels the unwanted noise by superposition.

(a) Describe what is meant by the principle of superposition.

(2)

.....

.....

.....

.....

*(b) Explain how the noise-cancelling headphones reduce the unwanted noise from the aircraft.

(3)

.....

.....

.....

.....

.....



DO NOT WRITE IN THIS AREA

DO NOT WRITE IN THIS AREA

DO NOT WRITE IN THIS AREA

(c) The graphs show the comparative variation in the intensity of frequencies, up to around 8 kHz, that are emitted from an aircraft and from human speech.

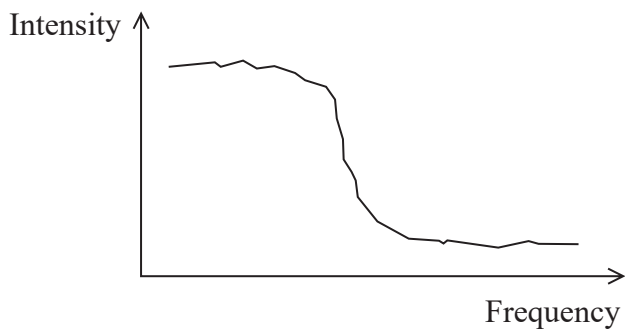

Aircraft

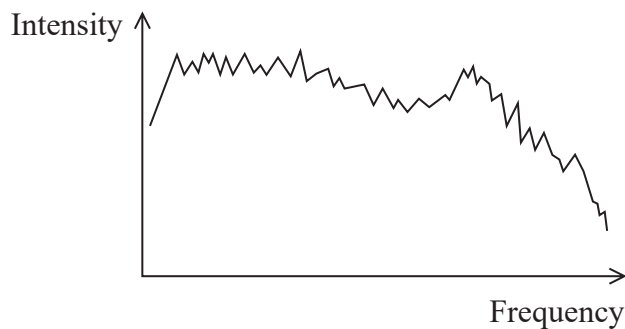

Human speech

(i) Explain why noise-cancelling headphones are better at reducing the noise from an aircraft than at reducing the sounds from human speech.

(3)

.....

.....

.....

.....

.....

.....

(ii) A concern has been raised that the additional sound wave produced by the headphones could damage the user's hearing.

Suggest whether this is a valid concern.

(1)

.....

.....

(Total for Question 18 = 9 marks)



19 Some light meters make use of the photoelectric effect.

*(a) Explain what is meant by the photoelectric effect.

(4)

.....

.....

.....

.....

.....

.....

.....

.....

.....

(b) The circuit shows a light meter.

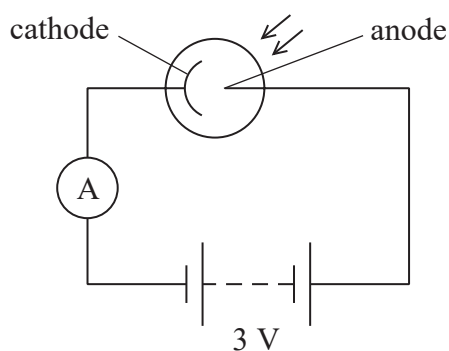

When light is incident on the cathode, electrons are released. These electrons are attracted to the anode causing a reading on the ammeter.

(i) Explain how the reading on the ammeter is a measure of the intensity of the light.

(3)

.....

.....

.....

.....

.....

.....

.....

.....



- (ii) The cathode has an area of $4.1 \times 10^{-3} \text{ m}^2$. The reading on the ammeter is 0.61 A.
Determine the minimum intensity of the light in W m^{-2} .

(3)

Minimum light intensity = W m^{-2}

- (iii) Caesium has a work function of 4.32 eV.

Determine whether caesium can be used as the cathode in the light meter to measure the intensity of light of frequency $2.2 \times 10^{14} \text{ Hz}$.

(4)

(Total for Question 19 = 14 marks)

TOTAL FOR SECTION B = 70 MARKS
TOTAL FOR PAPER = 80 MARKS



List of data, formulae and relationships

Acceleration of free fall	$g = 9.81 \text{ m s}^{-2}$	(close to Earth's surface)
Electron charge	$e = -1.60 \times 10^{-19} \text{ C}$	
Electron mass	$m_e = 9.11 \times 10^{-31} \text{ kg}$	
Electronvolt	$1 \text{ eV} = 1.60 \times 10^{-19} \text{ J}$	
Gravitational field strength	$g = 9.81 \text{ N kg}^{-1}$	(close to Earth's surface)
Planck constant	$h = 6.63 \times 10^{-34} \text{ J s}$	
Speed of light in a vacuum	$c = 3.00 \times 10^8 \text{ m s}^{-1}$	

Unit 1

Mechanics

Kinematic equations of motion	$v = u + at$ $s = ut + \frac{1}{2}at^2$ $v^2 = u^2 + 2as$
-------------------------------	---

Forces	$\Sigma F = ma$ $g = F/m$ $W = mg$
--------	------------------------------------

Work and energy	$\Delta W = F\Delta s$ $E_k = \frac{1}{2}mv^2$ $\Delta E_{\text{grav}} = mg\Delta h$
-----------------	--

Materials

Stokes' law	$F = 6\pi\eta rv$
-------------	-------------------

Hooke's law	$F = k\Delta x$
-------------	-----------------

Density	$\rho = m/V$
---------	--------------

Pressure	$p = F/A$
----------	-----------

Young modulus	$E = \sigma/\epsilon$ where Stress $\sigma = F/A$ Strain $\epsilon = \Delta x/x$
---------------	--

Elastic strain energy	$E_{\text{el}} = \frac{1}{2}F\Delta x$
-----------------------	--

DO NOT WRITE IN THIS AREA

DO NOT WRITE IN THIS AREA

DO NOT WRITE IN THIS AREA



Unit 2

Waves

Wave speed

$$v = f\lambda$$

Refractive index

$${}_1\mu_2 = \sin i / \sin r = v_1 / v_2$$

Electricity

Potential difference

$$V = W/Q$$

Resistance

$$R = V/I$$

Electrical power, energy and efficiency

$$P = VI$$

$$P = I^2R$$

$$P = V^2/R$$

$$W = VI t$$

$$\% \text{ efficiency} = \frac{\text{useful energy output}}{\text{total energy input}} \times 100$$

$$\% \text{ efficiency} = \frac{\text{useful power output}}{\text{total power input}} \times 100$$

Resistivity

$$R = \rho l/A$$

Current

$$I = \Delta Q / \Delta t$$

$$I = nqvA$$

Resistors in series

$$R = R_1 + R_2 + R_3$$

Resistors in parallel

$$\frac{1}{R} = \frac{1}{R_1} + \frac{1}{R_2} + \frac{1}{R_3}$$

Quantum physics

Photon model

$$E = hf$$

Einstein's photoelectric equation

$$hf = \phi + \frac{1}{2}mv_{\text{max}}^2$$

DO NOT WRITE IN THIS AREA

DO NOT WRITE IN THIS AREA

DO NOT WRITE IN THIS AREA



DO NOT WRITE IN THIS AREA

DO NOT WRITE IN THIS AREA

DO NOT WRITE IN THIS AREA

BLANK PAGE

